

CUSTOM METAL PROVIDER

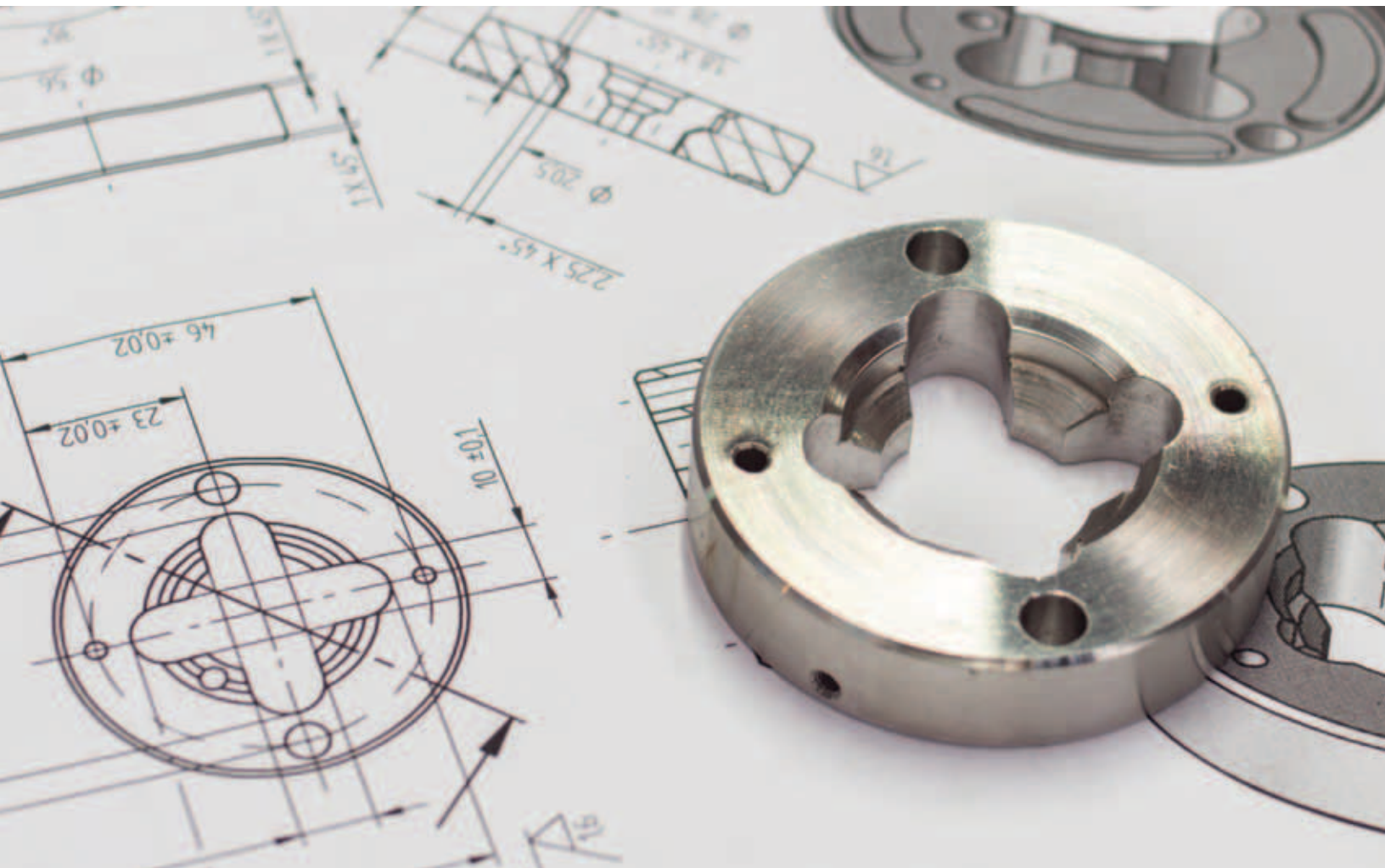

MONMET



Over 25 years metallurgical expertise

Monmet Ltd. is an innovative consulting and project management company, specializing in the design and supply of custom cast, forged and specialty metal products. By sourcing from a worldwide network of foundries and forging companies, we are able to offer our customers the best material and process that suits their needs. Our knowledge in alloy and process selection allows us to consistently deliver quality products to our clients, while reducing cost and cutting lead-times.

At Monmet, our parts meet or surpass industry standards for quality and performance, with physical quality and dimensional integrity meticulously checked against customer specifications and technical drawings. You can depend on us to provide you with the best manufacturing options available.

MONMET
specializes in the
supply of cast, forged
and specialty metal
products in all ferrous
and non-ferrous alloys.



Industries

At Monmet, we supply wear, abrasion and temperature resistant cast and forged components for a variety of industries.



MINING

Our quality products have been delivered throughout the world for crushing, grinding and pelletizing.



CEMENT

The cement and lime industries can rely on us to deliver the parts they need for their kilns, coolers and mills.



PULP & PAPER

Monmet specializes in the reverse engineering of components for the caustic environment of pulp and paper mills.



ENERGY

Monmet offers parts and solutions for the extreme environment of gas, steam and hydro turbines.



METALLURGICAL

Monmet supplies a variety of heat resistant cast and forged parts for precious metal refining, copper converters and aluminum smelters.



WORKSHOPS

Our cast and forged products are available to customers in machine, fabrication and gear shops.



CASTING APPLICATIONS

Mining

Grinding Mills
Crushers
Pelletizing

Cement/Lime

Kilns
Coolers
Roller Mills

Pulp & Paper

Wood Handling
Lime Kilns
Paper Machines
Refiners

Energy

Hydro Turbines
Gas Turbines
Steam Turbines
Coal Grinding Mills

Metallurgical

Copper Converters
Smelters
Nickel/Alum Refiners
Steel Mills

Workshops

Miscellaneous cast components for machine, fabrication & gear shops

Casting

Complex shapes in high or low volumes are ideally suited for the casting process. Monmet can help you choose the right option.

PROCESS OPTIONS

SAND	Weight	Min. ≤ 1 kg	Max. 125 t
-------------	--------	-------------	------------

INVESTMENT	Weight	Max. 115 kg
-------------------	--------	-------------

CENTRIFUGAL	Weight	In excess of 25 t
--------------------	--------	-------------------

Vertical

Diameter	Max. 6 m
Length	Max. 2.5 m

Horizontal

Diameter	Max. 1 m
Length	Max. 4.5 m

CONTINUOUS	Standard lengths up to 4 m or cut to size.
-------------------	--

Non-Ferrous

Diameter	Max. 405 mm
----------	-------------

BENEFITS

The benefits of the casting process become clear when producing parts with complex configurations. Shapes that call for design flexibility are well suited for casting. The casting process allows for the production of small or large quantities of complex parts in an economical manner.



Forging

Consistent strength and durability are qualities that can be achieved through the forging process. Monmet can supply you with the shapes and sizes you need.

PROCESS OPTIONS

OPEN-DIE	Weight	Min. 1 kg	Max. 160 t
CLOSED-DIE	Weight	Min. ≤ 1 kg	Max. 3,500 kg
SEAMLESS ROLLED RINGS	Weight Diameter	Max. 65 t Max. 9.5 m	

BENEFITS

Forgings are regularly used when strength, reliability, economy and resistance to shock and fatigue are important. Forged materials offer the desired degree of high or low temperature performance, ductility, hardness and machinability.

TYPICAL SHAPES

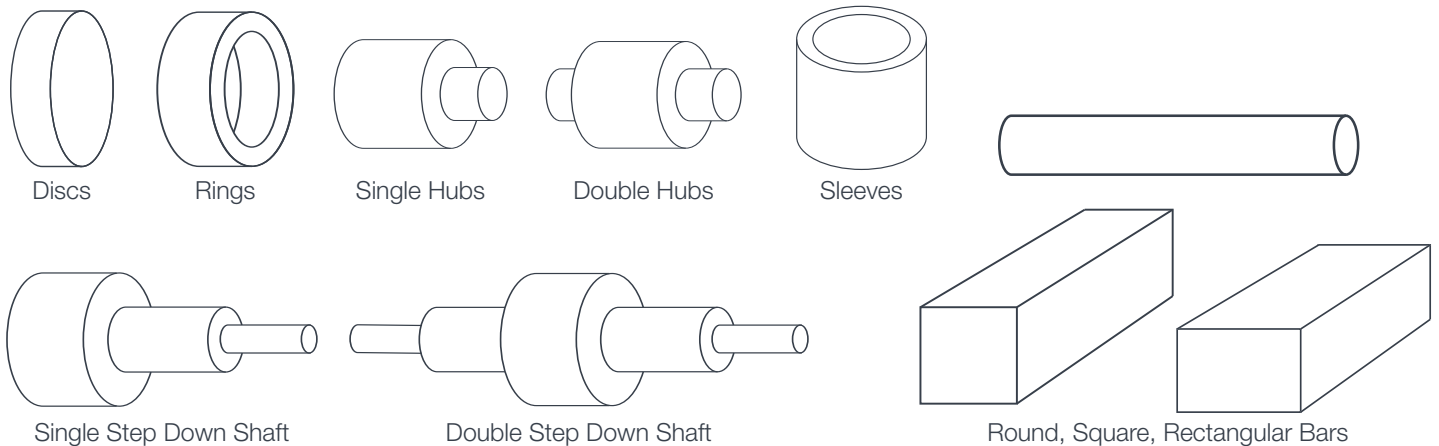

Services

Equipment repair and maintenance are at the heart of our services. Monmet can provide you with cost-effective options.

POWER TRANSMISSION

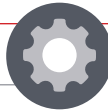

We can offer power transmission products for most heavy industrial applications. Monmet has the expertise to provide cost-effective solutions for gear replacements and gearbox repairs.

FABRICATION & MACHINING



Monmet offers a large range of machining and fabricating capabilities. This gives our customers full manufacturing options from start to finish. We excel in the repair and refurbishment of heavy industrial equipment.

TOOLING & PATTERN MAKING



Monmet can supply you with the appropriate type of tooling or patterns to manufacture your part in the most economical manner.

COATINGS & RESURFACING



We offer a variety of coating processes that can enhance or repair metal components. Coating or resurfacing parts can extend the wear life of new parts. It can also restore and prolong the life of older components.

ENGINEERING & DESIGN



We work closely with our clients and strive to understand their metallurgical needs. Our goal is to provide our clients with the improved engineered parts they are looking for.

QUALITY ASSURANCE



Under our quality assurance program, every job is inspected and approved by our qualified personnel. Mill test reports with certified chemical and physical properties can be provided with all our shipments.



Materials Supplied

Monmet supplies cast and forged components in an array of materials and sizes – from less than 1 kg to over 125 t.

FERROUS ALLOYS	
STEEL	ALLOY
	AUSTENITIC
	CARBON
	STAINLESS
	TOOL
IRON	AUSTEMPERED DUCTILE
	DUCTILE
	GREY
	HIGH CHROME
	MALLEABLE
	NI-HARD
	NI-RESIST
NON-FERROUS ALLOYS	
BRONZE	ALUMINUM
	COPPER
	HIGH-LEADED
	LEADED
	MANGANESE
	NICKEL
	PHOSPHOR
	SILICON

SPECIALTY ALLOYS
ALUMINUM
COBALT
HASTELLOY®
INCOLOY®
INCONEL®
MAGNESIUM
MONEL®
TITANIUM
TUNGSTEN
WASPALLOY®
ZINC



LOOKING FOR UNIQUE MATERIALS AND METAL SHAPING OPTIONS?

Talk to our specialists and find other ways of forming and shaping metal. There are a variety of options aside from casting and forging, such as powdered metals, extrusions and stamping. We will take your project requirements into consideration and suggest an option that is best for you.

We are here to help.

The numerous options that are available when choosing casting and forging can be complicated. When you come to Monmet, we will walk you through them.

THE MONMET DIFFERENCE

We offer alternative options in process design. This makes it possible for Monmet to offer you the opportunity to develop cost effective products and solutions that meet the challenges of today's industrial operations.

TRUSTED PARTNERS & SEAMLESS PROCESSES

Monmet Ltd. works with a worldwide network of foundries and forge shops that specialize in numerous processes. This allows us to fulfill any request—either from preliminary sketches, engineering drawings, or samples (new or used), on time and within budget.



CUSTOM SOLUTIONS

OUR GOAL IS TO OFFER YOU THE BEST MATERIAL, PROCESS AND PRODUCTION FACILITY THAT SUITS YOUR NEEDS.



QUALITY SERVICE

WE ARE COMMITTED TO PROVIDING YOU WITH THE BEST CUSTOMER SERVICE POSSIBLE.



CUSTOMER COMMITMENT

WE UNDERSTAND THE CHALLENGES YOU FACE AND THE NEED FOR COST-EFFECTIVE SOLUTIONS.

TALK TO US TODAY

Our metal specialists are ready to help you find the product you need. Call us **514-788-6007** or Email us info@monmet.com



MONMET